



INSTALLATION INSTRUCTIONS

P/N C2109

Congratulations! You have just purchased the finest set of leaf spring traction bars available. To be sure that the end result is everything you want it to be, make certain:

- 1) that your application is correct
- 2) that you have all parts listed in Parts List (below)
- 3) that you read the directions through carefully **BEFORE** proceeding
- 4) that you have the proper tools required

Tools needed for installation are as follows: wrenches and socket set (including deep well sockets) electric drill and bits, two jack stands, and hydraulic floor jack. It is **highly recommended** that the stock spring housing pockets be reinforced with a brace made of 1/4" thick material. The brace must contact the front and rear of the housing pockets and extend upward to the axle housing tube. See figure #4. **NOTE:** These traction bars may not work with the stock (factory) rear sway bar. If that is the case, it will have to be removed or modified.

PARTS LIST

4	U-BOLTS	4	7/16" NYLON LOCKNUTS
2	7/16" SQUARE BOLTS	8	7/16" FLAT WASHERS
2	RUBBER BUMPERS	4	7/16" STD NUTS
2	3/8" NYLON LOCKNUTS	8	1/2" STD NUTS
16	1/2" FLAT WASHERS	8	1/2" NYLON LOCKNUTS

INSTALLATION INSTRUCTIONS

1. Check rear springs for broken leaves. Replace if necessary.
2. Jack up the rear of the car and place two jack stands under the frame member in front of the rear spring. Allow the rear axle housing to hang, resting on the springs.
3. Disconnect the shock absorber at the lower mounting point. Remove stock lower spring pad plate and U-bolts, if U-bolts are used.

CAUTION: Be sure U-bolt does not interfere with brake lines, tires, etc. when installed.

4. After removing the stock lower spring pad plate, position the bar under spring center bolt so that center bolt is in hole in middle of traction bar spring plate.

NOTE: Do not remove rubber insulation pad from between spring and rear axle mounting pad unless you plan to use these bars for competition only. Metal spacer plates will have to be fabricated if the rubber pads are eliminated.

Make sure the spring centering bolt **DOES NOT PROTRUDE** through the spring pad too far contacting the traction bar. If it does, cut the centering bolt off even with the nut

5. Install U-bolts through spring pad. Install nuts. See figure #2, locations A and B. At this point, make sure all shock brackets (figure #3, location A) clear backing plates, tires, and wheels. Cut off those shock brackets that may interfere. Determine which of the shock brackets you are going to use and make certain that your shock-attaching bolt will go through the hole in the bracket. If not, drill hole larger to accept bolt.
6. Repeat procedures 6 and 7 for other side traction bar.
7. With both traction bars installed on rear housing pads, jack the rear axle housing up until all the weight of the car is on the springs, as though the car was in normal ride position. Check the distance between the top front of bar and the spring where the rubber bumper would make contact. This distance should be equal to the height of the rubber bumper included in the kit. Refer to figure #2, location E. If this height is not correct, the bar will have to be shimmed (up or down) at the housing pad with aluminum degree wedges. These can be purchased from your Competition Engineering dealer, part #C7025.

NOTE: Competition Engineering's "S/S Competition" Traction Bars are designed and built to minimize shimming, an exclusive feature. It is likely that little adjustment will have to be made.

If the height is correct, let the rear housing down into an extended position again and install rubber bumpers.

8. **U-bolt Tightening Procedure:** Tighten these bolts evenly, starting with the square U-bolt at the front of the bar (figure #2, location F). Thread 7/16" nuts onto U-bolt about 3/4 of the way up the thread. Install flat washers over legs of U-bolt and slide U-bolt over leaf spring and through traction bar forward bracket. Refer to figure #1, location D. Adjust nuts so that square U-bolt contacts top of leaf spring. See figure #2, location F. Install washers and special 7/16" nylon locknuts on bottom of U-bolts and tighten securely. **IMPORTANT: DO NOT USE THESE U-BOLTS TO ADJUST HEIGHT OF CAR.** Reinstall shock absorbers.
9. **Fine Tuning Procedures: IMPORTANT** – Do not use front U-bolts to adjust heights of the car. This can cause excess preloading, possibly resulting in severe torque steer and broken axles. Be sure tire pressures are equal. A good set of high performance replacement shocks, such as Competition Engineering P/N 2740 rear; 65-70 Mustangs P/N C2630; or 71-73 Mustangs P/N C2640 for the front. **IF TRACTION IS UNEQUAL, THE FOLLOWING PROCEDURE SHOULD CORRECT TORQUE STEER.**
 If the right rear tire traction is greater than the left, the car will pull to the left. To correct this, raise the front of the left (driver's) side traction bar with the use of wedges or lower the right side bar. This procedure can be reversed if torque steer causes the bumpers at the beginning of each competitive season.

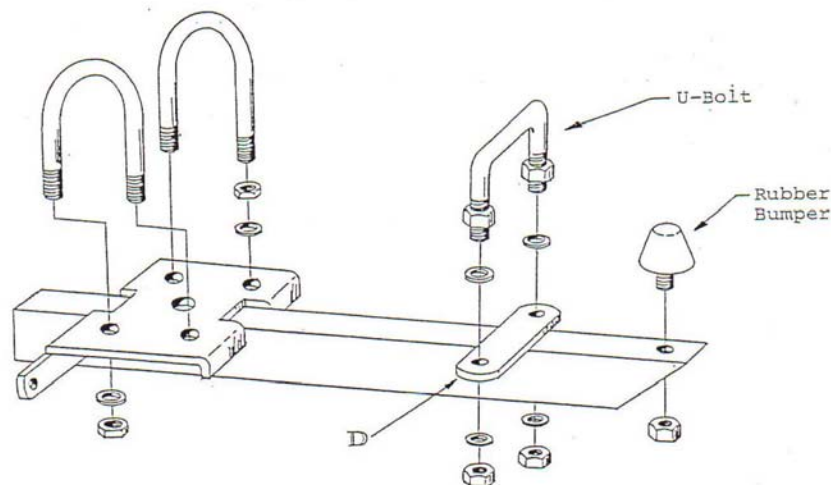

Figure 1

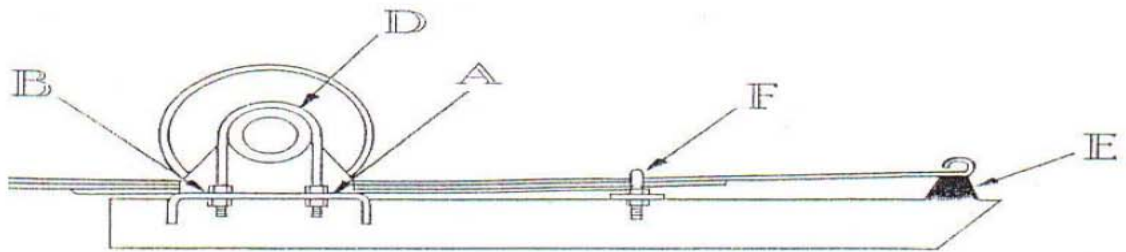

Figure 2

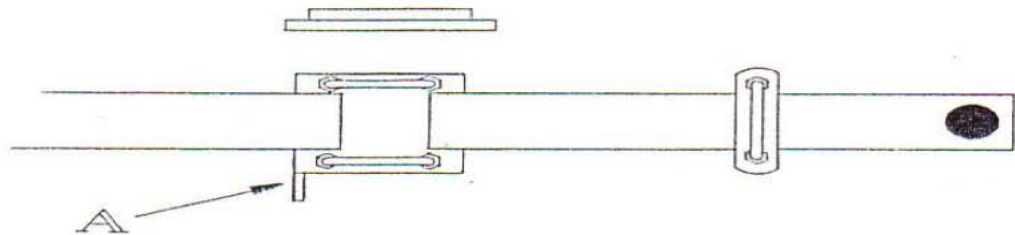

Figure 3

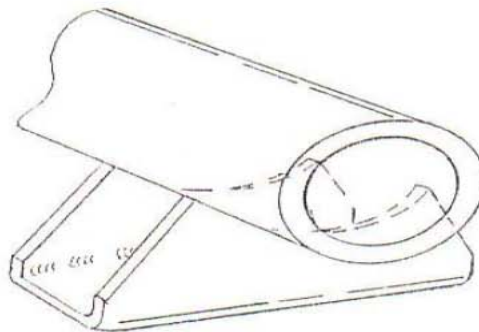

Figure 4

*For Technical Assistance, call Competition Engineering's Tech Line at
(203) 458-0542, 8:30am-5:00pm Eastern Time*

COMPETITION ENGINEERING

80 Carter Drive • Gullford, CT 06437

Phone: (203) 453-5200 • Fax: (203) 453-6906

Rev. B
020912

C2109INST

Visit Us At www.competitionengineering.com